

Cognitive Systems

Foundations of Information Processing
in Natural and Artificial Systems

Lecture 3

Levels of Information Processing
and Knowledge Representation



Levels of Information Processing and Knowledge Representation

Overview

- Levels of information processing in cognitive systems
- Symbolic vs. connectionist models of cognition
- Knowledge representation

Complex Systems

- The problem: understanding cognition
- Cognitive systems are **complex systems**
- **Complex systems** (of any kind) cannot be understood by simply extrapolating the properties of their elementary components
- For example ...

Examples of Complex Systems

- Social / political systems
 - elementary components?
 - higher-level components?
- Thermodynamic systems
 - elementary components?
 - higher-level components?

Understanding Complex Systems

- Effects in complex systems can be described at several levels
 - each level captures different aspects
- Microscopic and macroscopic descriptions should not be inconsistent
- In theory, all levels of explanation should form a coherent whole; but sometimes they are incommensurable
- Cognitive systems as information processing systems are investigated at three different levels: ...

Marr's Three Levels (1982)

- **Computational theory**
 - constraints for mapping input information to output information
- **Representation and algorithm**
 - definition of information processing operations
- **Hardware implementation**
 - physical realization of the algorithm within a physical system

An Example: The Thermostat

(Palmer 1999)

- The computational level

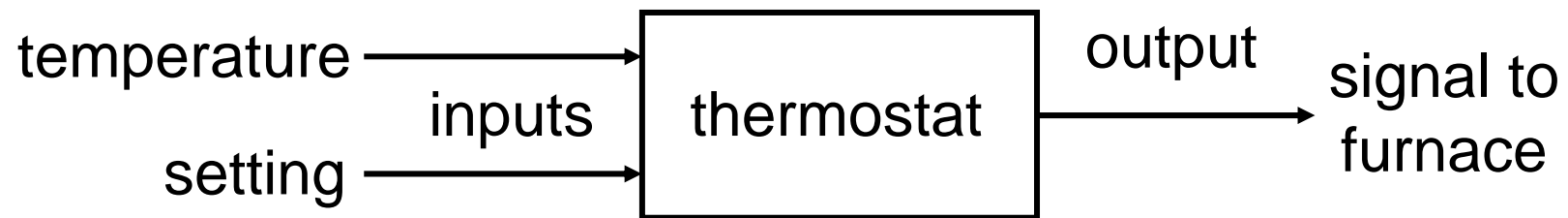

An Example: The Thermostat

- The computational level (cont'd)

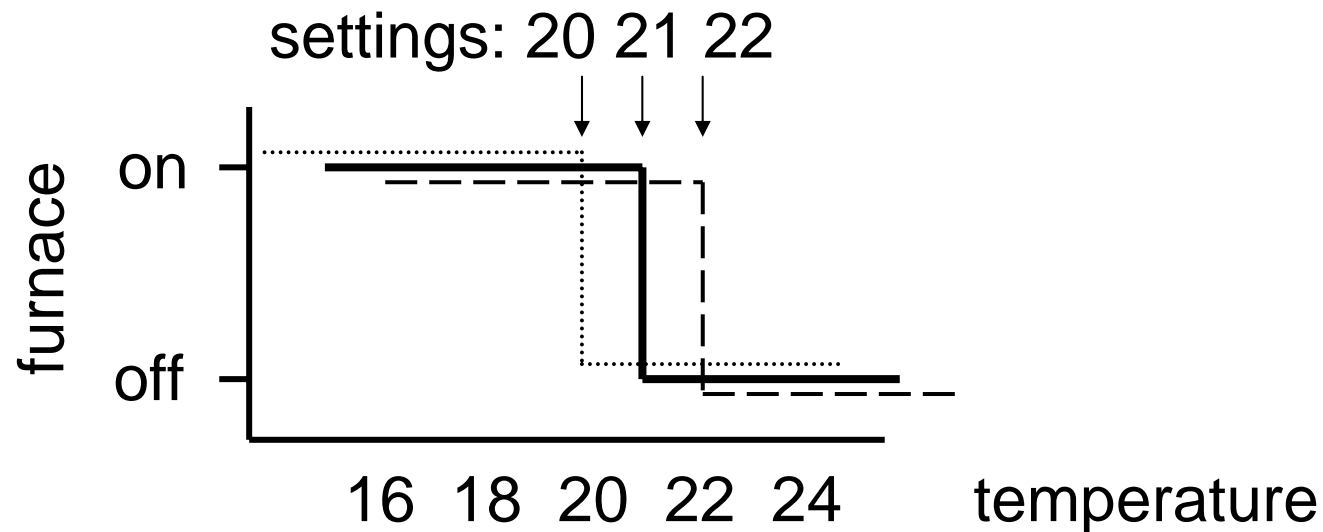

$$O(T, S) = \begin{cases} 1 & \text{iff } T < S \\ 0 & \text{iff } T \geq S \end{cases}$$

An Example: The Thermostat

- The algorithmic level

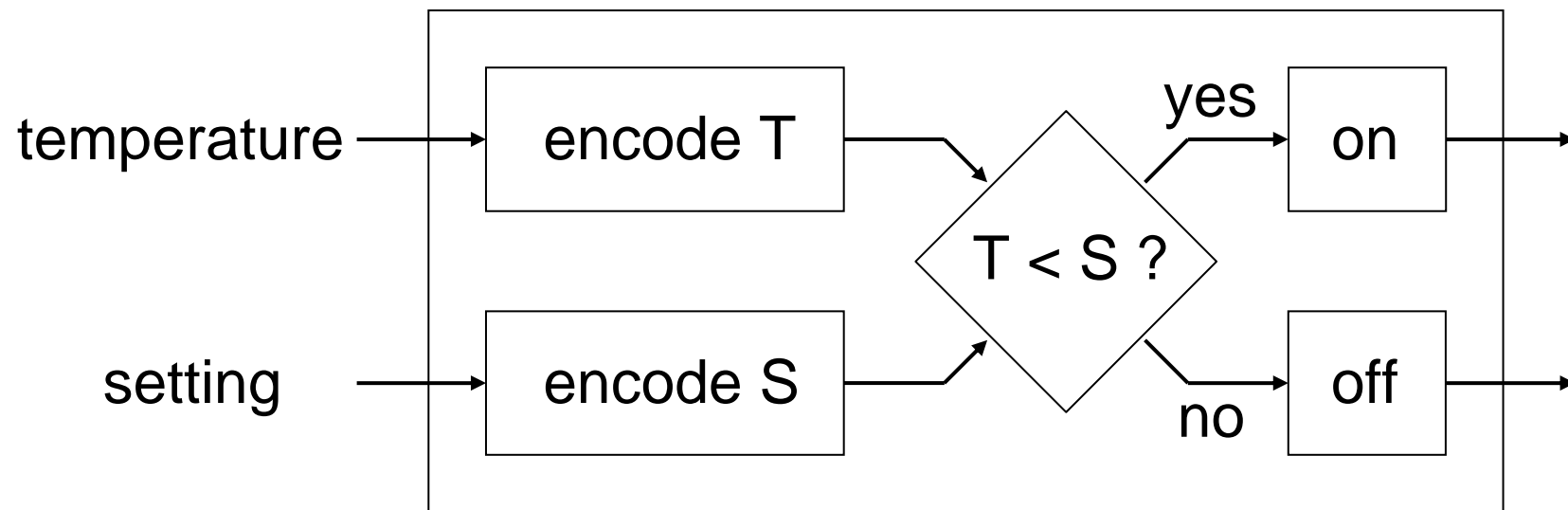

An Example: The Thermostat

- The implementation level

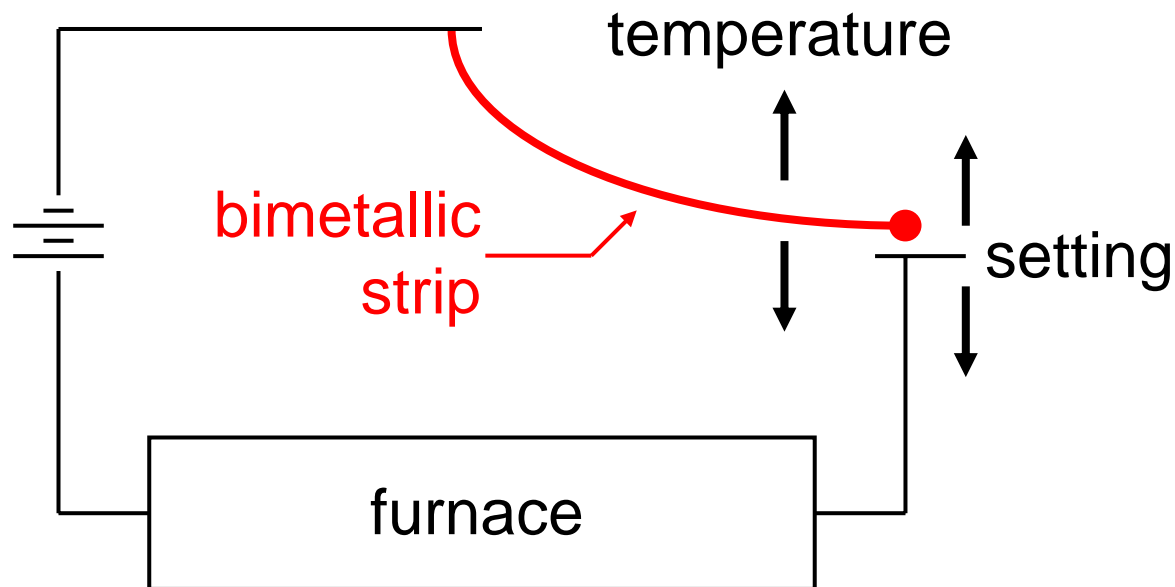

In Cognitive Systems?

- The computational level
 - constraints for mapping input information to output information
 - for the overall system (e.g. in small systems)
 - for subsystems within a complex cognitive system (e.g. perceptual subsystems, language processing subsystems)

In Cognitive Systems?

- The algorithmic level
 - definition of information processing operations
 - description of how the computational level performs its operations (e.g. structural description of memory, algorithmic description of learning processes)

In Cognitive Systems?

- The implementation level
 - physical realization of the algorithm within a physical system
 - remember: ‘cognitive systems’ applies to both natural and artificial systems

natural CSs

neurons
neural structures
neural systems
brains
humans / animals

artificial CSs

program instructions
methods, functions
programs
computers
robots

Architectures of Cognition

- Description of cognitive systems as ‘architecture’ (Simon & Kaplan 1989)
- An architecture identifies components at different levels
 - neurons, brain regions, memory systems
 - design of the architecture depends on what the architecture focuses on

Levels of the Architecture

(Simon & Kaplan 1989)

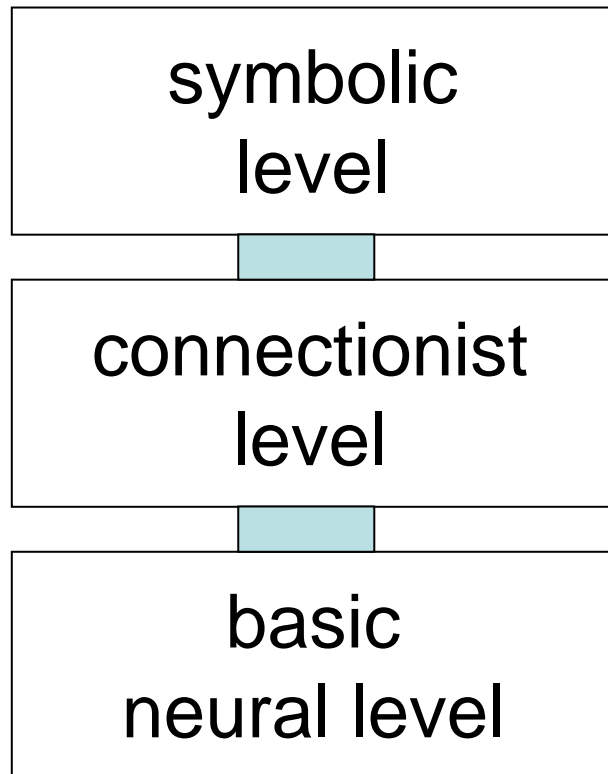

!

- these levels and Marr's levels are orthogonal to each other
- each of the architecture's levels can be investigated at each of Marr's levels

Levels of the Architecture

(Simon & Kaplan 1989)



- **computational specification**
 - function to be performed
- **algorithmic description**
 - interaction between components
- **implementation**
 - realization of the function in neuronal networks

Levels of the Architecture

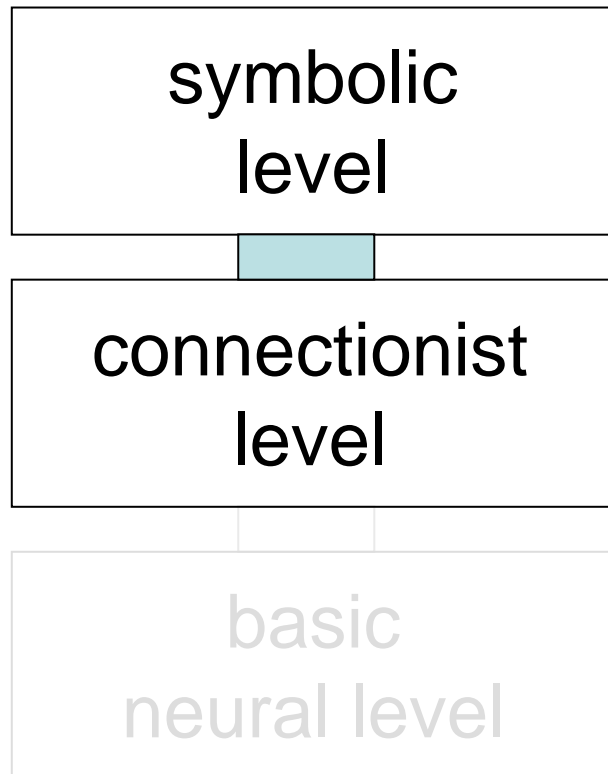

- Models of cognitive systems are typically defined as

symbolic models

connectionist models

Connectionist and Symbolic Models

- **Connectionist Models**
 - highly simplified and schematized neurons
 - interconnected in a network structure
- **Symbolic Models**
 - symbols organized in memories
 - symbolic models are abstract higher-level models

Levels of Information Processing and Knowledge Representation

Overview

- (1) Levels of information processing in cognitive systems
- (2) Symbolic vs. connectionist models of cognition
 - symbolic models
 - connectionist models
- (3) Knowledge representation

The Physical Symbol System Hypothesis (PSSH)

Lecture 1

- Fundamental thesis of Cognitive Science:

A physical symbol system has the necessary and sufficient means for general intelligent action.

Herbert A. Simon & Alan Newell

- Brains and computers are symbol systems.

Symbol Manipulation = Information Processing

Lecture 1

- Information is processed by syntactic operations on formal symbols
- Synthesis of syntactic operations allows forming more abstract symbols (concepts)
- Meaning emerges from syntactic operations

Requirements on Symbolic Architectures (Newell et al. 1989)

1. Flexible behavior as function of the environment
2. Adaptive, rational, and goal-oriented behavior
3. Real-time operation
4. Operation in rich, complex, and detailed environment
 - perception of changing details
 - use of stored knowledge
 - control of complex motoric systems
5. Use of symbols and abstractions

Requirements on Symbolic Architectures (2)

6. Use of language
7. Learning from environment and from experience
8. Acquisition of capabilities through the environment
9. Live autonomously within a society of other cognitive systems
10. Self-awareness and sense of self

(list not claimed to be complete)

Symbolic Models of Cognition

- Symbolic models explain cognition on the computational (or functional) level, rather than on the basis of neural structures and mechanisms
 - radical difference on the implementation level in neural and symbolic cognitive systems

Components of Symbolic Architectures

- Memory
- Symbols
- Operations
- Interpretations

the first four components
form the symbol system

- Interaction facilities with external world

Memory

- Consists of symbol structures that contain symbol tokens
- Independently modifiable
- Sufficient memory available

Symbols

- Symbol tokens form patterns in structures
- Symbol tokens provide access to other symbol structures in memory
- Sufficiently many symbols available

Operations

- Processes that take symbol structures as input and produce symbol structures as output

Symbol systems are considered to be universal computers (like Turing machines)

Interpretations

- Processes that take symbol structures as input and produce behavior by executing operations

Interaction with External World

- Perceptual and motor interfaces
 - symbol system embedded in a ‘body’ acting in the real world
- Buffering and interrupts
 - to interface between the symbol system and perception / motor subsystems
- Real-time demands for action
- Continuous acquisition of knowledge

Two Examples

memories

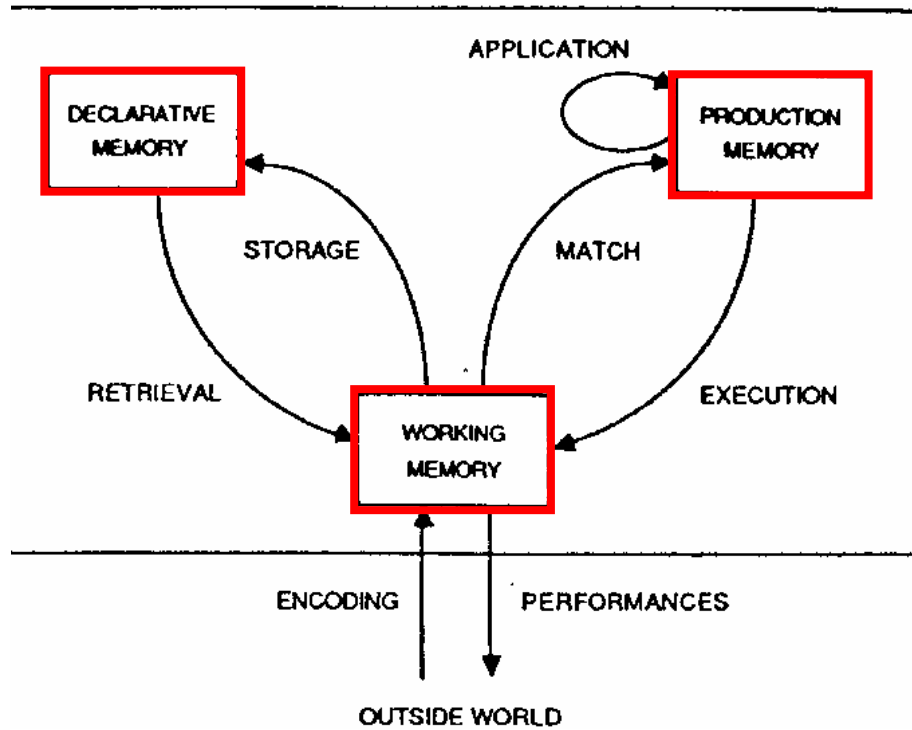

ACT* (Anderson 1983)

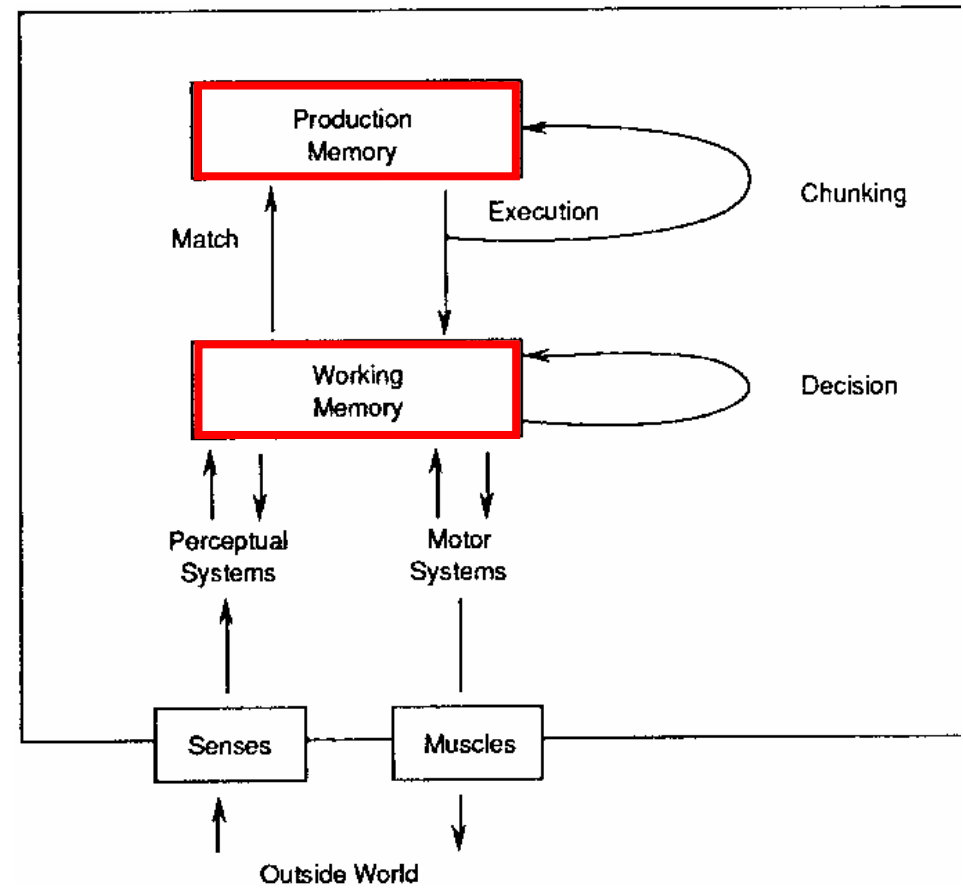

Soar (Laird et al. 1987)

Two Examples

symbols

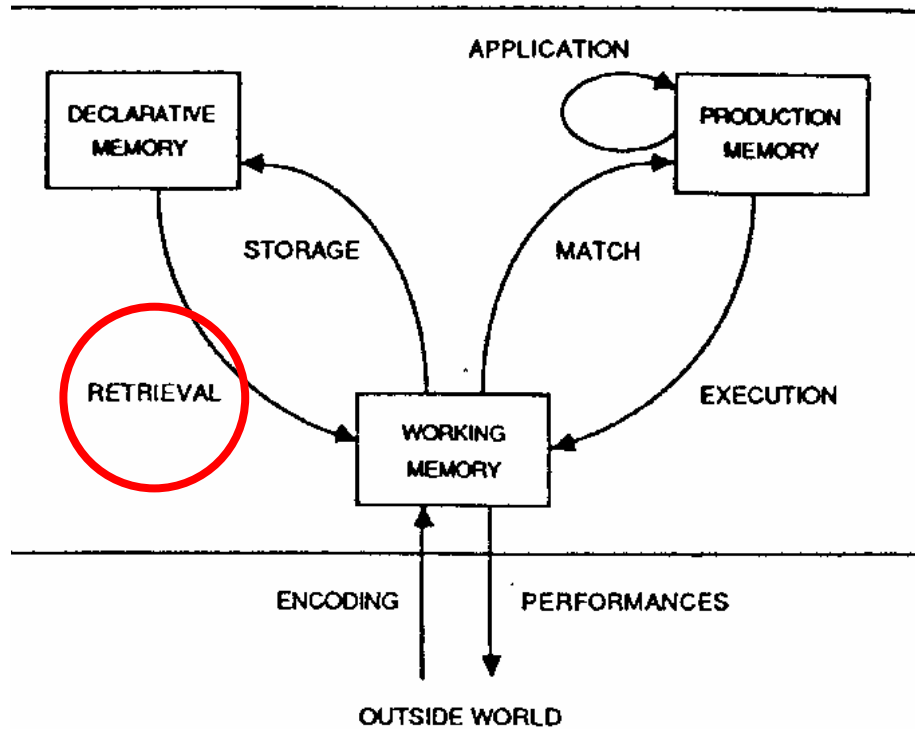

ACT* (Anderson 1983)

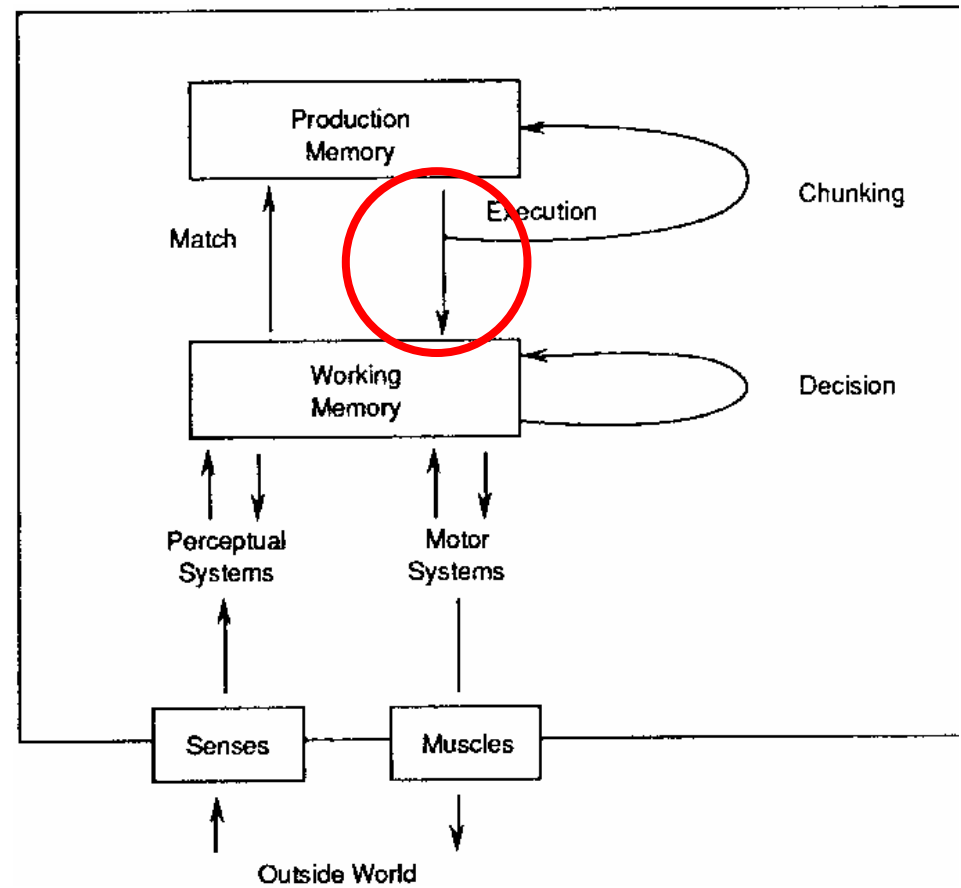

Soar (Laird et al. 1987)

Two Examples

operations

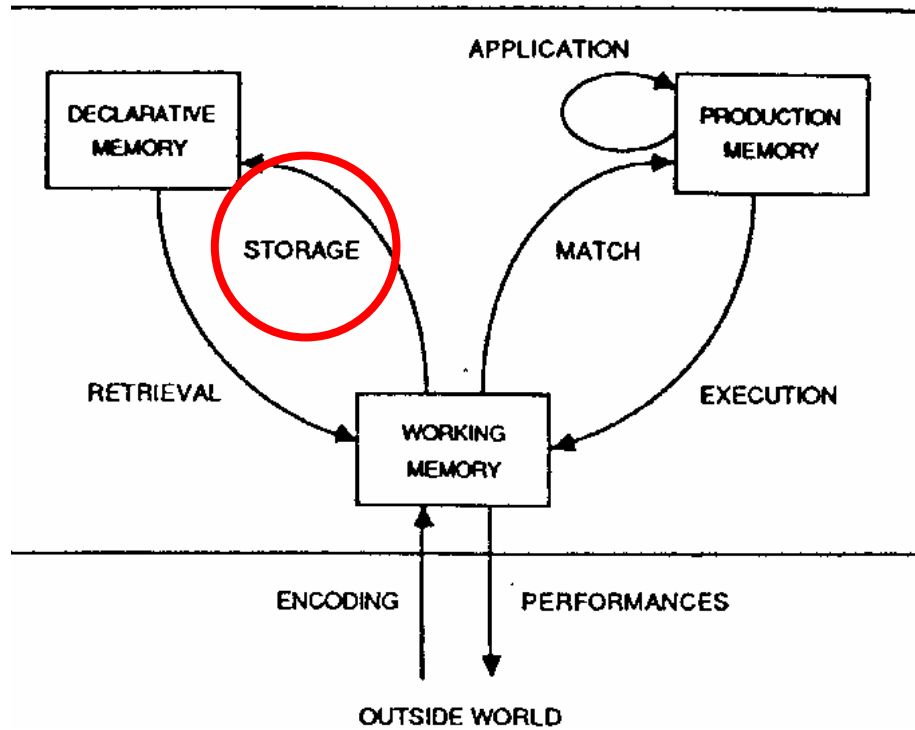

ACT* (Anderson 1983)

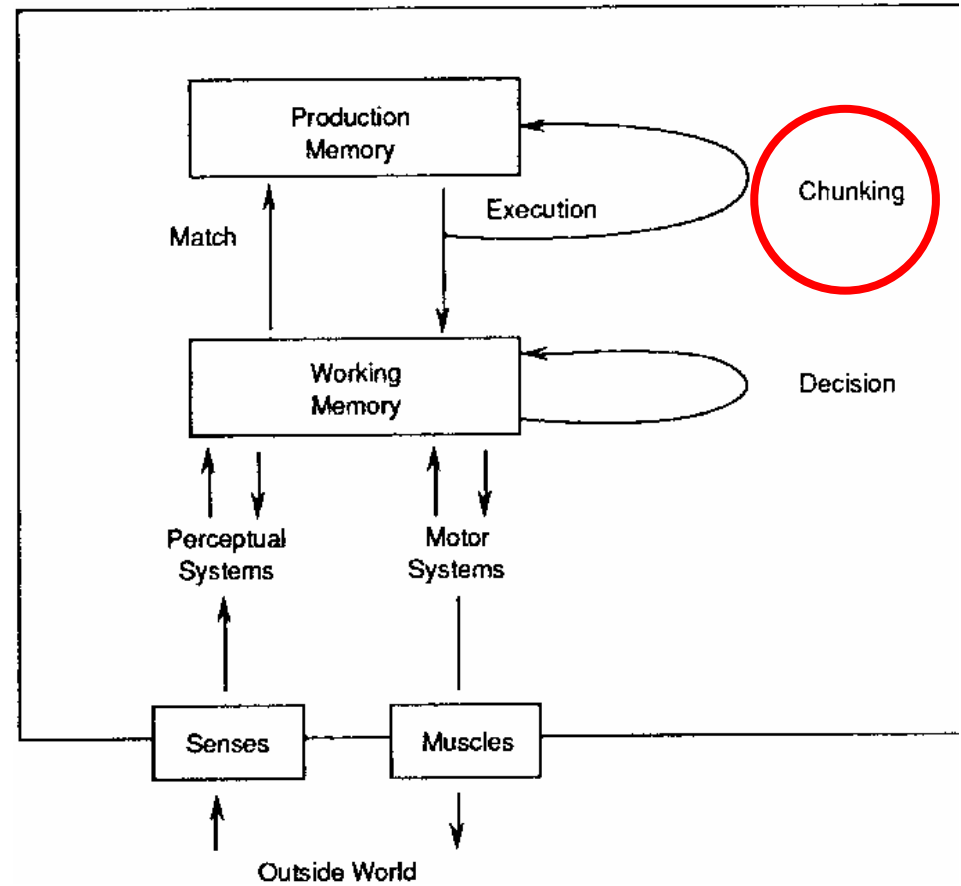

Soar (Laird et al. 1987)

Two Examples

interpretations

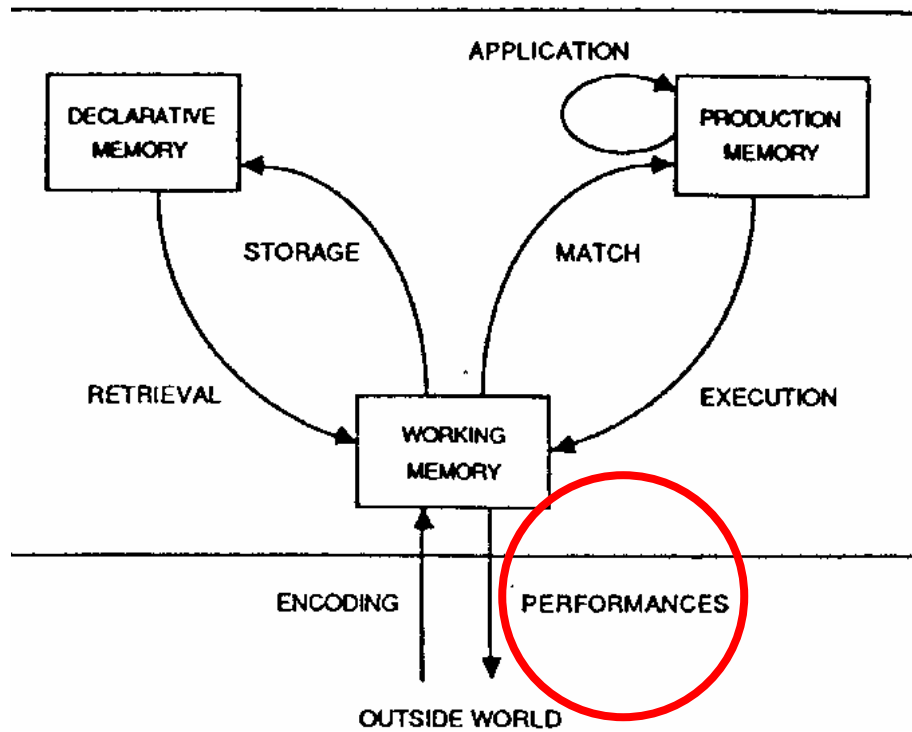

ACT* (Anderson 1983)

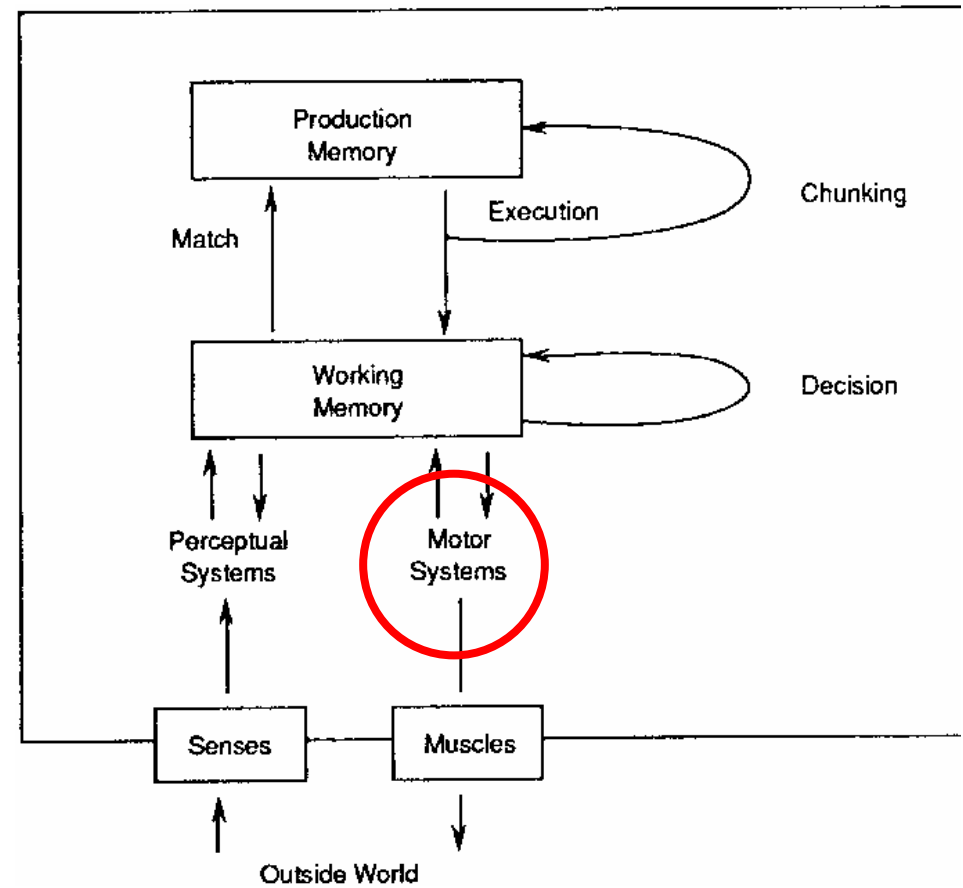

Soar (Laird et al. 1987)

Two Examples

interaction with external world

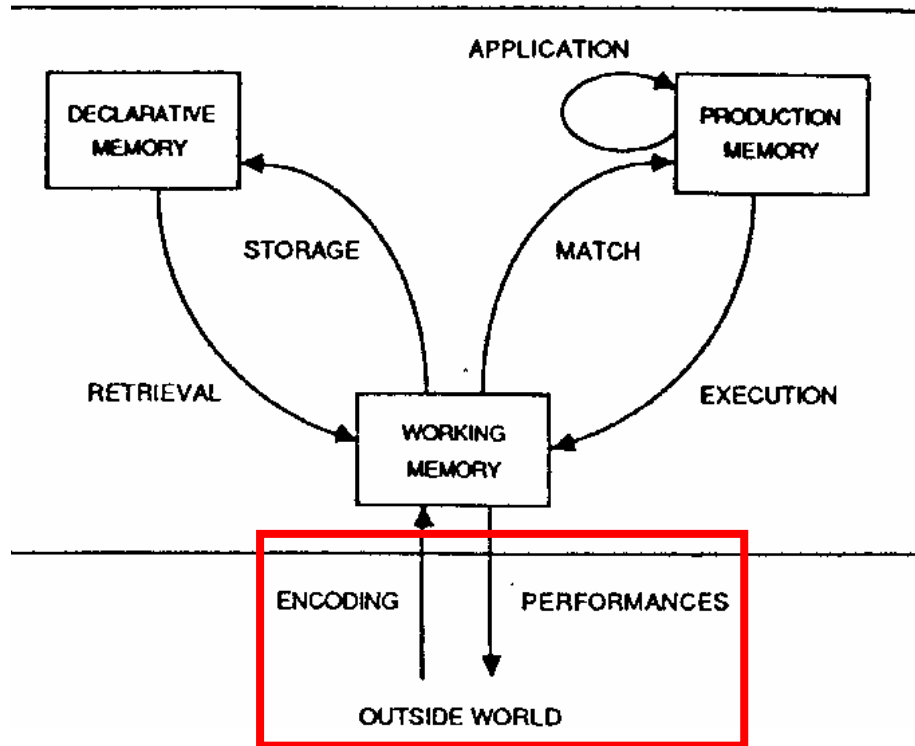

ACT* (Anderson 1983)

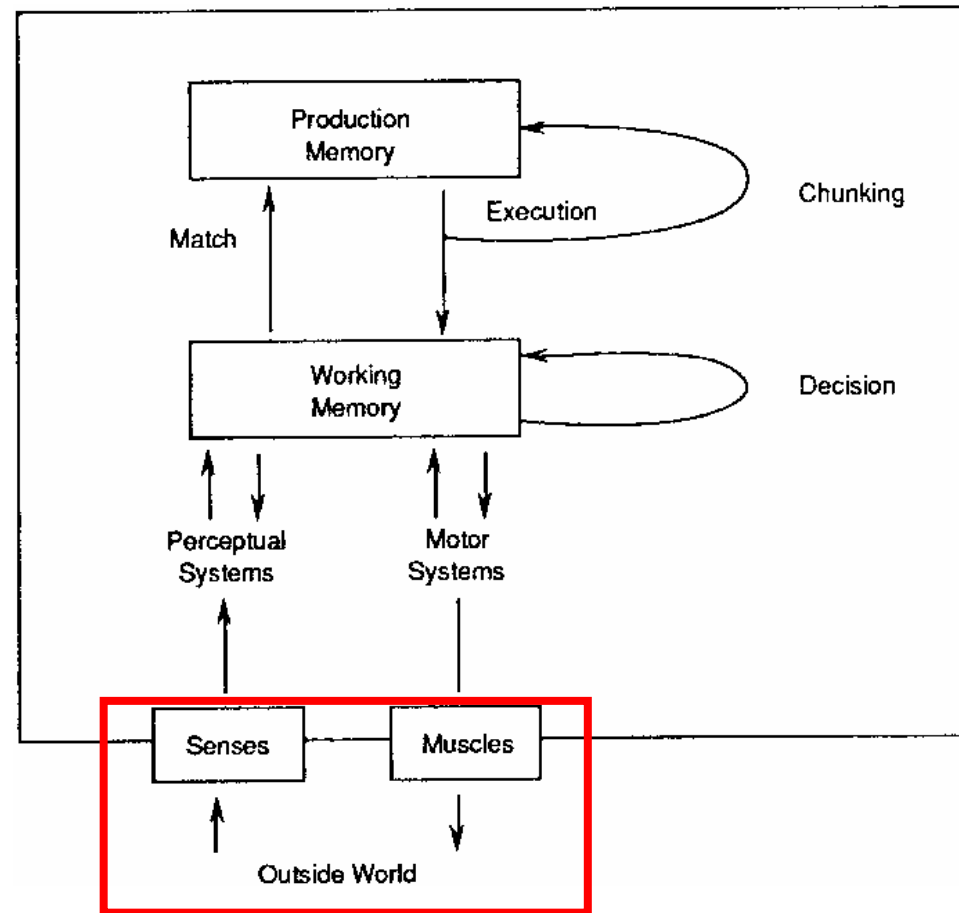

Soar (Laird et al. 1987)

Levels of Information Processing and Knowledge Representation

Overview

- (1) Levels of information processing in cognitive systems
- (2) Symbolic vs. connectionist models of cognition
 - symbolic models
 - connectionist models
- (3) Knowledge representation

Connectionist Models of Cognition

- Symbolic models ignore the physical realization of intelligence in brains
- Physical structure influences the algorithms that may be used
- Connectionist models are neurally inspired
- “Brain-style” computation
- Artificial neuron as basic computing unit
- Computation through interaction of ‘neurons’

Neurons ...

- Neurons are slow
 - 10^6 times slower than microprocessors
 - “100-step program” (Feldman 1985)
- But there are many of them
 - in the human brain about 10^{11}
- Neurons operate in parallel
- “Knowledge” is encoded in the neural connections
 - one neuron connects to up to 10^5 other neurons
- no explicit states, but implicit representation in the neural structure

Seven Components of connectionist models

1. Set of processing units
2. State of activation
 - defined over processing units
3. Output function
 - maps state of activation to output
4. Pattern of connectivity among units

Seven Components (cont'd)

5. Activation rule

- computes new level of activation from inputs and current state

6. Learning rule

- modifies patterns of connectivity based on experience

7. Environment in which the system operates

Connectionist Model

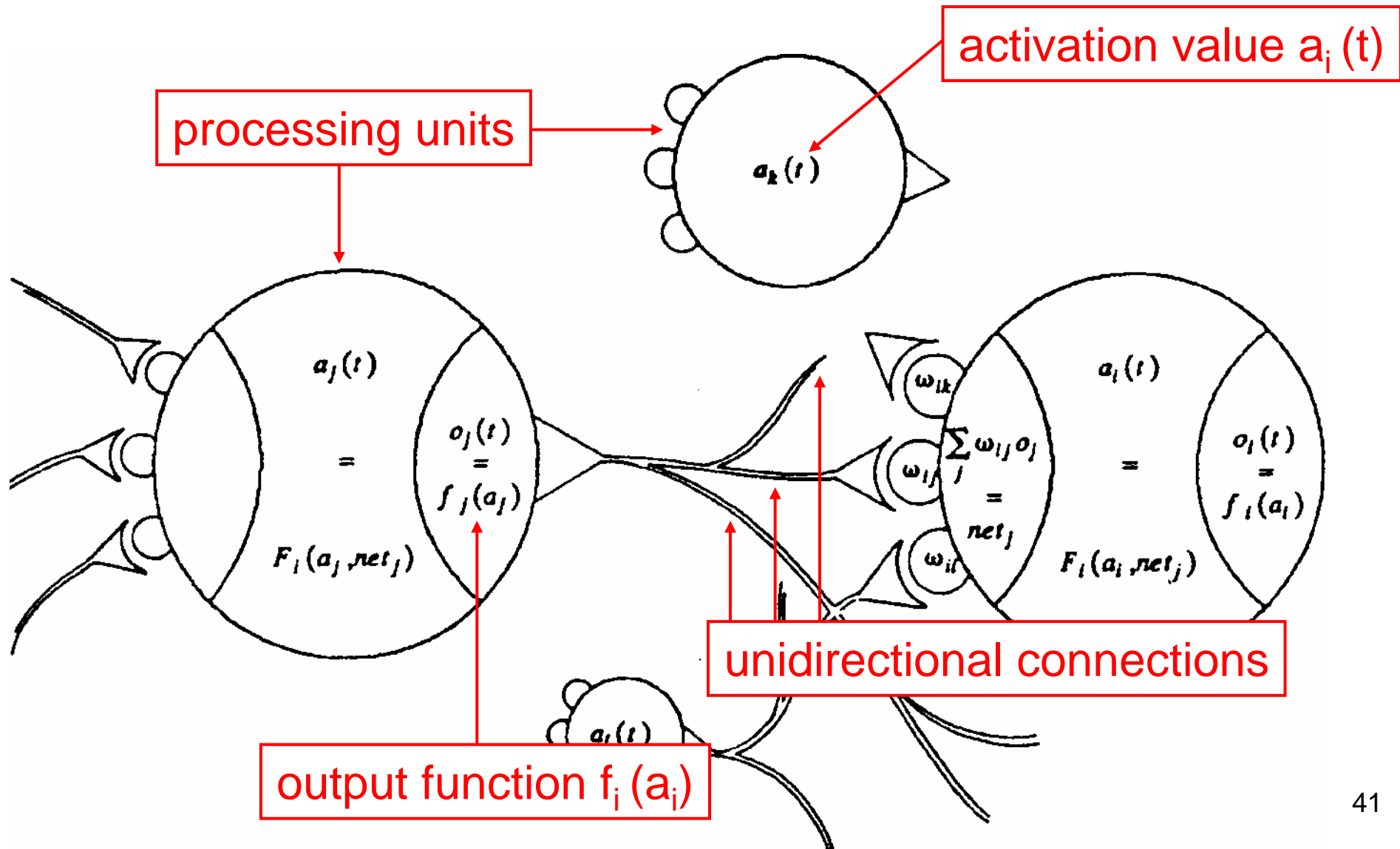

Connectionist Model

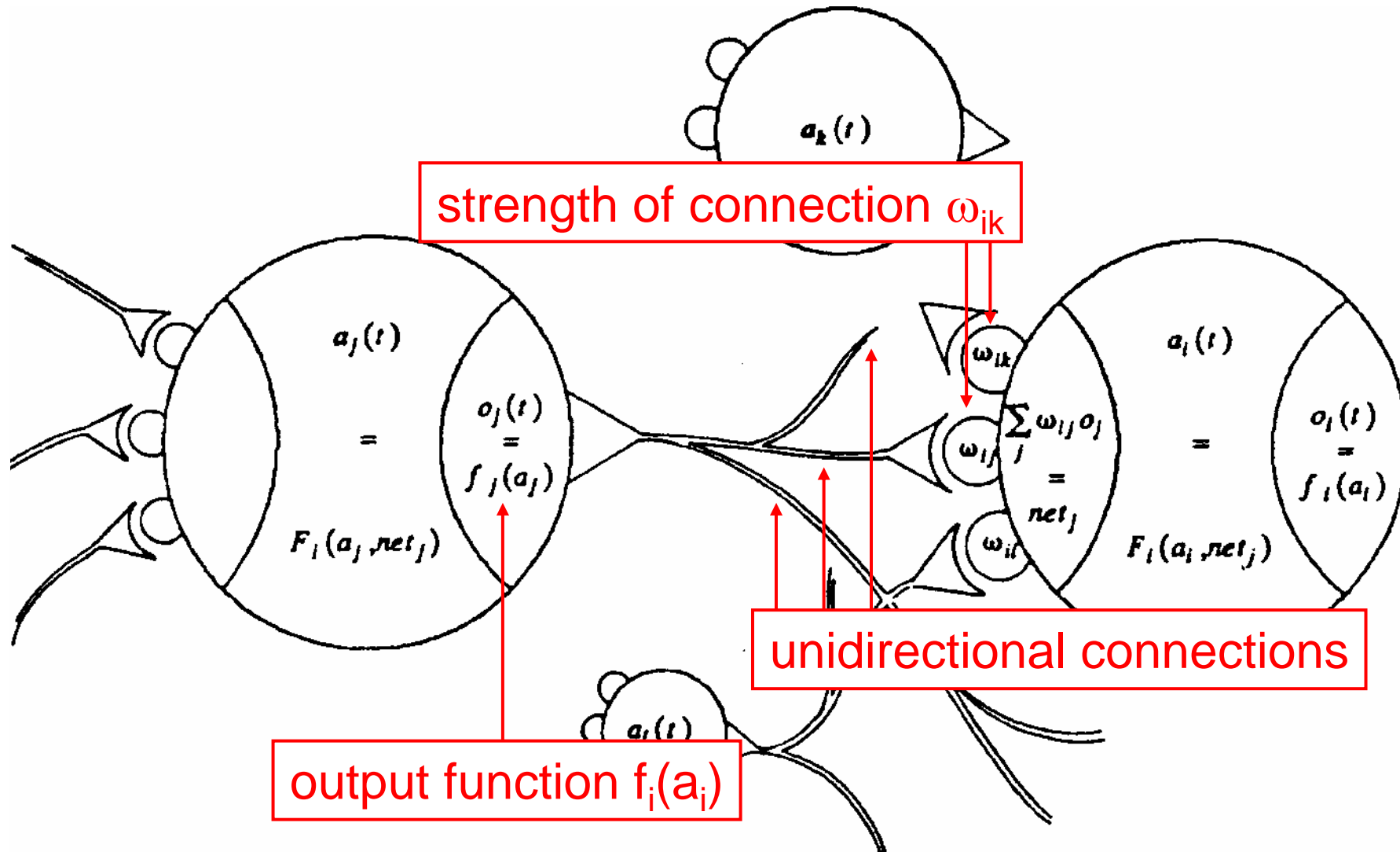

Connectionist Model

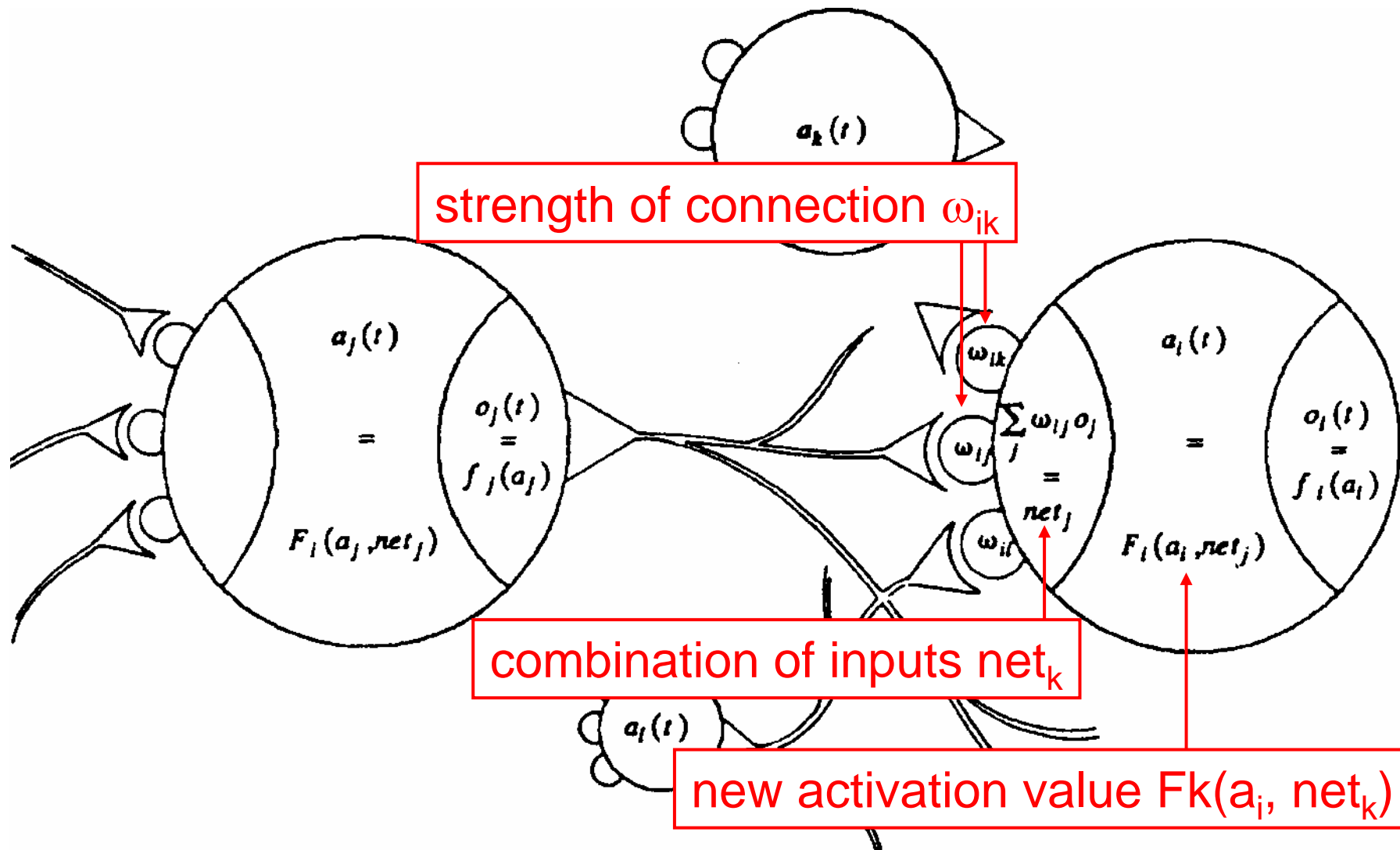

Remarks on Connectionist Models

- Connectionist systems represent knowledge in a distributed manner
 - “micro features”
 - no one-unit to one-concept matching (i.e. no localism)
- Types of units
 - input units, hidden units, output units
- Strength of connection represents the connectivity among units
 - excitatory connection, inhibitory connection, no connection

Learning in Connectionist Systems

- Learning through modification of patterns of connectivity
 - development of new connections
 - loss of existing connections
 - modification of strengths of existing connections
- Hebb's (1949) learning rule:

If a unit u_i receives an input from another unit u_k , then, if both are highly active, the weight ω_{ik} from u_k to u_i should be strengthened.

Levels of Information Processing and Knowledge Representation

Overview

- Levels of information processing in cognitive systems
- Symbolic vs. connectionist models of cognition
- **Knowledge representation**

Internal Representations

Lecture 1

- Environmental information is transformed into neurological structures and meaningful symbols (internal representation)
- This representation is processed in connection with other internally available information about the world (knowledge)
- The result is transformed into actions on the environment

Knowledge Representation

- How can a symbol system represent the external world?
- Symbols are not themselves representations of the external world
 - symbols provide internal representation function
- Representation of the external world is a function of the entire cognitive system

Knowledge Representation

- A **representation** is a formal system for making something explicit in the system, together with the specification of how the system does this
- A **description** of something in a representation uses the representation to describe a specific entity in the world
- An example: ...

Knowledge Representation: An Example

- Numeral systems are formal systems for **representing** numbers; a specific number encoded in a numeral system is a **description** of that number
- Description of the number '12' in different representations

12 XII 1100 C dz.

Next week

Foundations of visual perception:

retina, receptors, and visual cortex